

SINGLE WINDOW (Wavelength Flattened) and DUAL WINDOW (Broadband) COUPLERS

AOFR's fused biconic taper coupler technology and advanced production techniques make for consistent high-performance couplers that are designed for the end users' specific applications. AOFR's unique manufacturing process allows true wideband operation with no water absorption peak at 1383nm. A variety of standard coupler packages, as well as pigtail options and connectorization are available, if required. Non-standard devices can be supplied upon request. All AOFR couplers conform to stringent environmental and mechanical standards to give high reliability for a variety of field applications.

FEATURES

- Completely passive
- Low loss
- Proven high reliability
- Low PDL
- No water absorption peak at 1383nm

APPLICATIONS

- Active monitoring
- CATV networks
- Fiber-in-the-loop
- Fiber optic test equipment and sensing

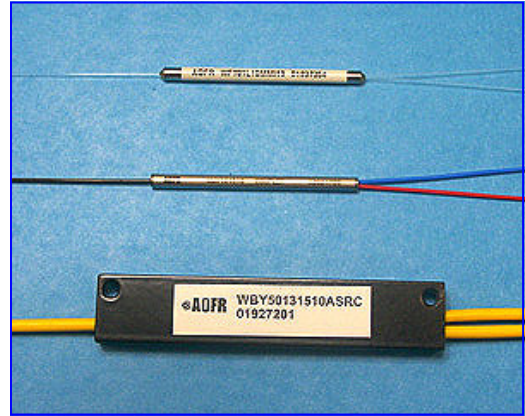

SPECIFICATIONS

Configuration	1x2 or 2x2	
Operating Wavelength	Wideband 1260-1580nm	Wavelength Flattened 1260-1360nm or 1430-1580nm
Coupling Ratio (%)	Maximum Insertion Loss (dB) Primary/Secondary	Maximum Insertion Loss (dB) Primary/Secondary
50/50	3.7/3.7	3.5/3.5
45/55	3.2/4.1	3.0/4.0
40/60	2.7/4.7	2.6/4.5
35/65	2.3/5.3	2.2/5.1
33/67	2.2/5.5	2.1/5.4
30/70	2.0/6.0	1.9/5.8
25/75	1.6/6.8	1.6/6.6
20/80	1.3/7.8	1.3/7.6
15/85	1.0/9.2	1.0/9.0
10/90	0.8/11.2	0.7/10.9
5/95	0.5/14.4	0.5/14.2
Return Loss/Directivity	>55dB	
Operating Temperature	-40°C to 85°C	
Fiber type	Corning SMF28e Photonic (200kpsi)	

AOFR Pty Limited

2 Faulding Street
Symonston ACT
Australia 2609
PO Box 7125
Canberra Business Centre ACT, 2610
Ph:+61 2 6206 2222
Fax: +61 2 6280 6393

Sales Contacts:

North & South America - email: sales@aofr.com

Europe & Middle East - email: sales@aofr.com

Japan (Industrial) - OptoSirius Corp.- Ph: +81 3 5963 6377, Fax: +81 3 5963 6388, email: aihara@optosirius.co.jp

Japan (Telecom) - Nissho Electronics Corp. - Ph:+81 3 3544 8211, Fax: +81 3 3544 8280. email:o-devices@nissho-ele.co.jp

China - ComStar Communications Ltd.- Ph: +85-2-2536-9737, Fax: +85-2-2536-9978, email: hongkong@comstarcom.com

Australia/New Zealand - CoverTel - Ph: +61 (0)3 932 83699, Fax: +61 (0)3 932 82644, email: cliff_lever@covertel.com.au

ORDERING INFORMATION

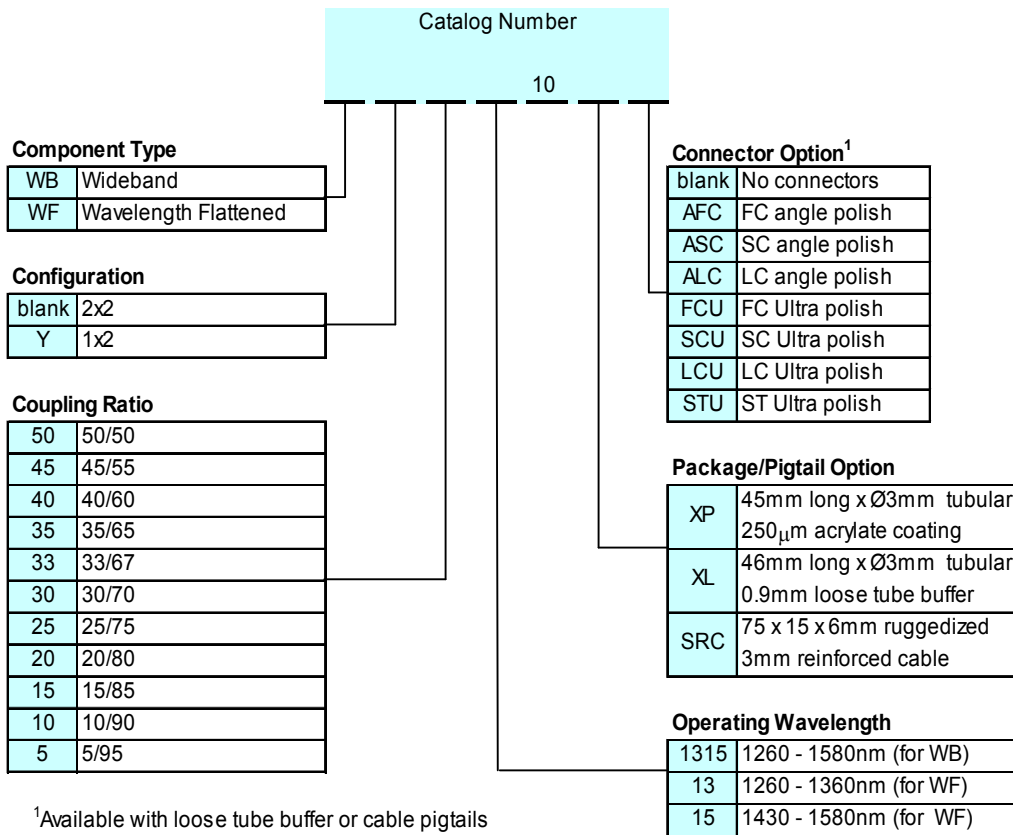

PACKAGE OUTLINES

