

### MONOLITHIC 1X3 SPLITTERS

AOFR's single mode monolithic 1x3 passive optical couplers are manufactured using AOFR's proven fused biconic taper process, resulting in an extremely compact, highly reliable, cost competitive device that complies with Telcordia specifications for fiber optic branching components. The dual-window devices are ideal for use in video distribution networks and FITL networks operating from 1260nm to 1625nm. AOFR's unique manufacturing process allows true wideband operation with no water absorption peak at 1383nm. Both dual window (wideband) and single window (wavelength flattened) versions are available including optimized C-Band performance.

#### FEATURES

- Compact packaging
- Dual or single window operation
- Completely passive operation
- Proven high reliability
- Low insertion loss
- Low PDL
- No water absorption peak at 1383nm

#### BENEFITS

- Dual and Single window operation.
- 3mm diameter x 45 mm long tubular package
- Manufactured to Telcordia 1209 and 1221 guidelines

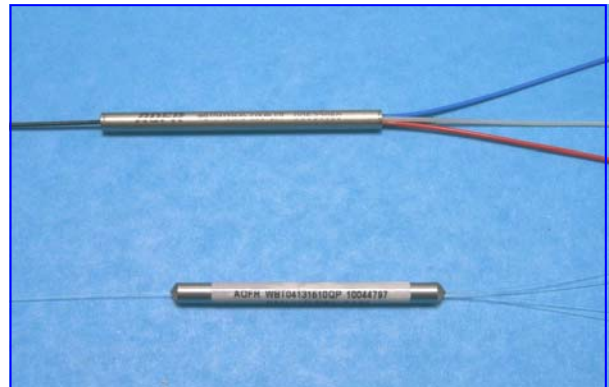

### SPECIFICATIONS

Configuration	1x3	
	Wideband 1260-1580nm	Wavelength Flattened 1260-1360 or 1430-1580nm
Operating Wavelength		
Maximum Insertion Loss (dB)	6.0	5.7
Typical Insertion Loss (dB)	5.0	5.0
Return Loss/Directivity	>55dB	
Operating Temperature	-40°C to 85°C	
Fiber type	Corning SMF28e Photonic (200kpsi)	

#### AOFR Pty Limited

2 Faulding Street  
Symonston ACT  
Australia 2609  
PO Box 7125  
Canberra Business Centre ACT, 2610  
Ph: +61 2 6206 2222  
Fax: +61 2 6280 6393

#### Sales Contacts:

**North & South America** - email: [sales@aofr.com](mailto:sales@aofr.com)

**Europe & Middle East** - email: [sales@aofr.com](mailto:sales@aofr.com)

**Japan** - Nissho Electronics Corp. - Ph: +81 3 3544 8211, Fax: +81 3 3544 8280. email: [o-devices@nissho-ele.co.jp](mailto:o-devices@nissho-ele.co.jp)

**China** - ComStar Communications Ltd. - Ph: +85-2-2536-9737, Fax: +85-2-2536-9978, email: [hongkong@comstarcom.com](mailto:hongkong@comstarcom.com)

**Australia/New Zealand** - CoverTel - Ph: +61 (0)3 932 83699, Fax: +61 (0)3 932 82644, email: [cliff\\_lever@covertel.com.au](mailto:cliff_lever@covertel.com.au)

### ORDERING INFORMATION

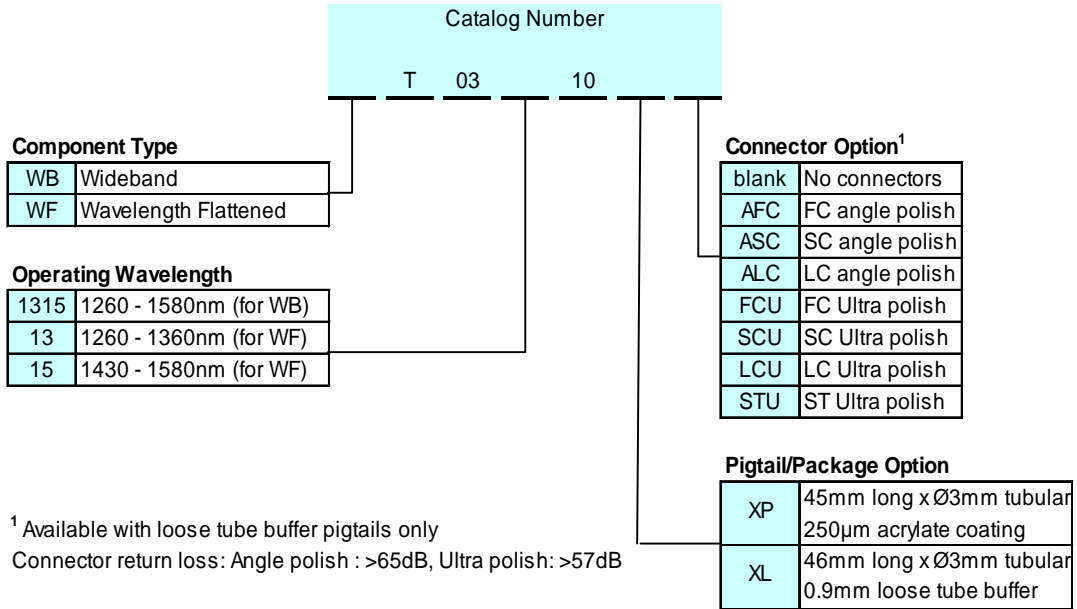

### PACKAGE OUTLINES

