

1480/1550 MULTIPLEXER FOR EDFA PUMPING

AOFR's 1480/1550 WDM are specifically designed to optimize the performance of Erbium Doped Fiber Amplifiers (EDFA's). AOFR's proven fused biconic taper (FBT) technology and advanced production techniques give high stability and reliability with high power handling capability. Pump WDMs are available in a small tubular package suited for OEM applications.

FEATURES

- Low insertion loss
- High pump coupling efficiency
- All fiber construction
- Stable environmental performance
- High power handling capability
- Proven FBT performance

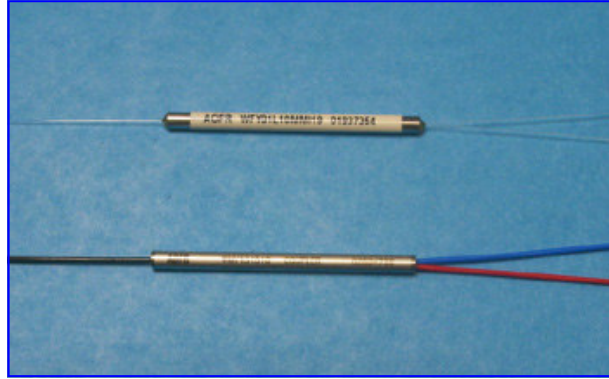

SPECIFICATIONS

Configuration	1x2
Operating temperature	-40°C to 85°C
Pump Insertion loss (1475-1485nm)	<0.4dB
Signal Insertion loss (1535-1565nm)	<0.9dB
PDL	<0.1dB
Return loss/Directivity	>55dB
Fiber Type	Corning SMF28e Photonic
Power handling	<4 Watts
Package	55mm long x Ø3mm

AOFR Pty Limited

2 Faulding Street
Symonston ACT
Australia 2609
PO Box 7125
Canberra Business Centre ACT, 2610
Ph:+61 2 6206 2222
Fax: +61 2 6280 6393

Sales Contacts:

North & South America - email: sales@aofr.com

Europe & Middle East - email: sales@aofr.com

Japan (Industrial) - OptoSirius Corp.- Ph: +81 3 5963 6377, Fax: +81 3 5963 6388, email: aihara@optosirius.co.jp

Japan (Telecom)- Nissho Electronics Corp. - Ph:+81 3 3544 8211, Fax: +81 3 3544 8280. email:o-devices@nissho-ele.co.jp

China - ComStar Communications Ltd.- Ph: +85-2-2536-9737, Fax: +85-2-2536-9978, email: hongkong@comstarcom.com

Australia/New Zealand - CoverTel - Ph: +61 (0)3 932 83699, Fax: +61 (0)3 932 82644, email: cliff_lever@covertel.com.au

ORDERING INFORMATION

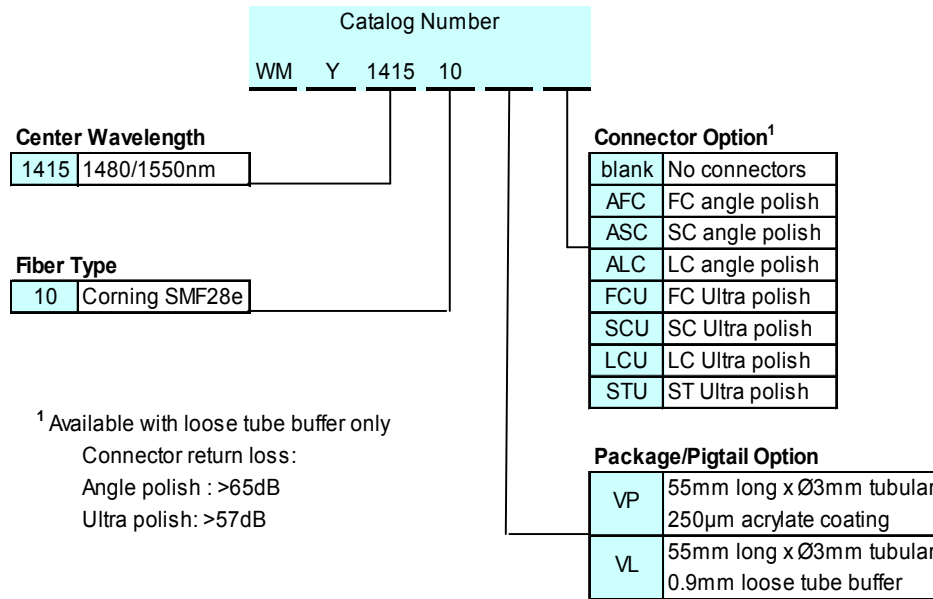

PACKAGE OUTLINES

